



## connectors

X0 control unit/ main terminal block  
 X1 control unit/ ballast, tubes  
 X2 control unit/ ballast, tubes/ shoulder tanner  
 X3 control unit/ ballast, facial tanner  
 X4 control unit/ ballast, facial tanner  
 X5 control unit/ exhaust fan  
 X6 control unit/external timer, decorative light  
 X6A control unit/deco light canopy, -back side  
 X7 control unit/ airconditioner  
 X8 exhaust fan  
 X9 air ventilation  
 X10 air ventilation body  
 X11 airconditioner  
 X12 condensate pump  
 X13 heat return, servo motor  
 X13A heat return, thermostat  
 X15 external timer  
 X14 decorative light insert front  
 X14A tube insert front  
 X17 connector in the backplate  
 X18A compressor unit

X18 connector canopy, tubes  
 X19 connector canopy, tubes  
 X20 connector canopy, tubes/decorative light  
 X21 connector canopy, facial tanner/thermal switch  
 X22 connector canopy, tubes  
 X23 connector canopy, tubes  
 X24 connector canopy, tubes  
 X25 connector back side, tubes/dekorative light  
 X26 connector back side, tubes/dekorative light  
 X27 connector base, tubes  
 X28 connector base, tubes  
 X29 decorative light canopy  
 X30 decorative light canopy inside  
 X31 aqua cool, aroma  
 X32 shoulder tanner  
 X33 pure air

E1 main control board/ start,power supply  
 E2 main control board/ body fan  
 E3 main control board/ relais output  
 E4 main control board/ remote start  
 E5 main control board/ error messages  
 E6 main control board/ power supply CPI  
 E9 music amplifier/ power supply  
 E10 relais board fresh/ power supply  
 E11 relais board fresh/ relais output  
 E12 relais board fresh/ relais output  
 E15 LED transformer, power supply  
 E16 LED transformer output  
 E17 LED power supply  
 E19 speed control, exhaust air fan  
 E20 Interface/Audio Switch ,power supply

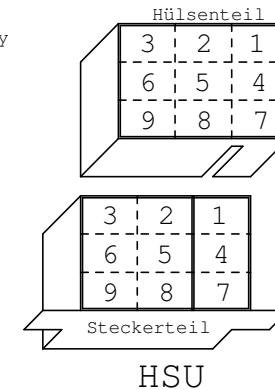

connection of the main power supply  
 3 x 220V / 60Hz ~ 4 x AWG 6

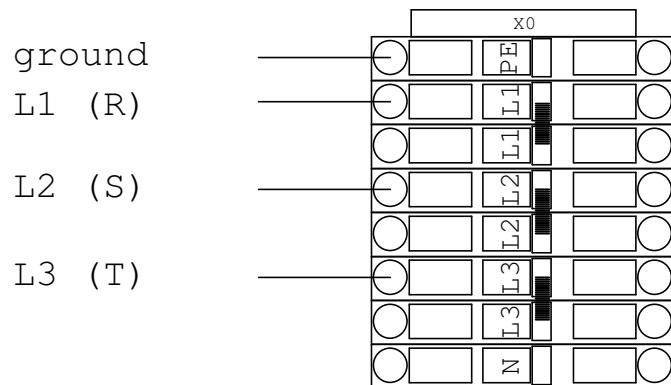

connection to external timer  
 with an floating relais output

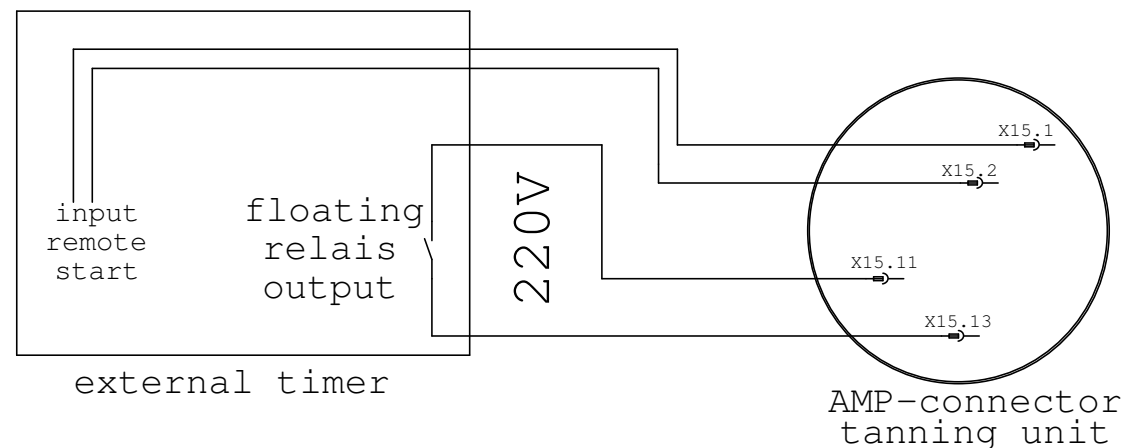

				Datum	17.03.06	KBL- Solarien		MS 7900 CPI_USA	MS 7900_CPI_220V_usa	=	Änderungen vorbehalten			
			Bearb.	R.Schmidt										
			Gepr.											
Zust.	Änderung	Datum	Name	Norm		Urspr.	Ers.f.	Ers.d.		MS7900_CPI_03/0705us	Blatt 2 von 10Bl.			

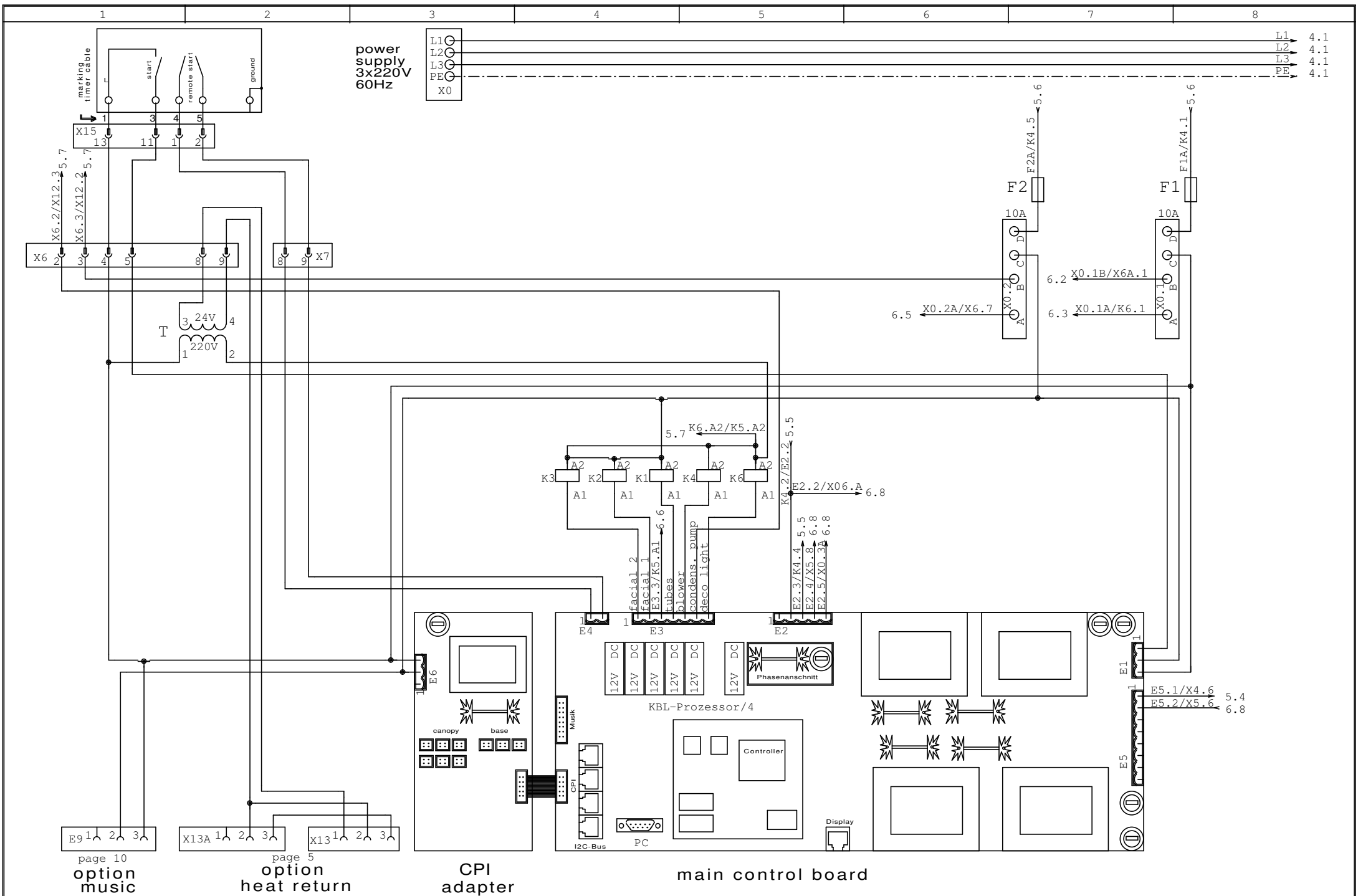

				Datum	17.03.06		MS 7900 CPI_USA		= Änderungen vorbehalten
				Bearb.	R.Schmidt		MS 7900 CPI_USA		+
				Gepr.			MS7900_CPI_03/0705us		Blatt 3
Zust.	Änderung	Datum	Name	Norm	Urspr.	Ers.f.	Ers.d.	MS7900_CPI_03/0705us	von 10Bl.

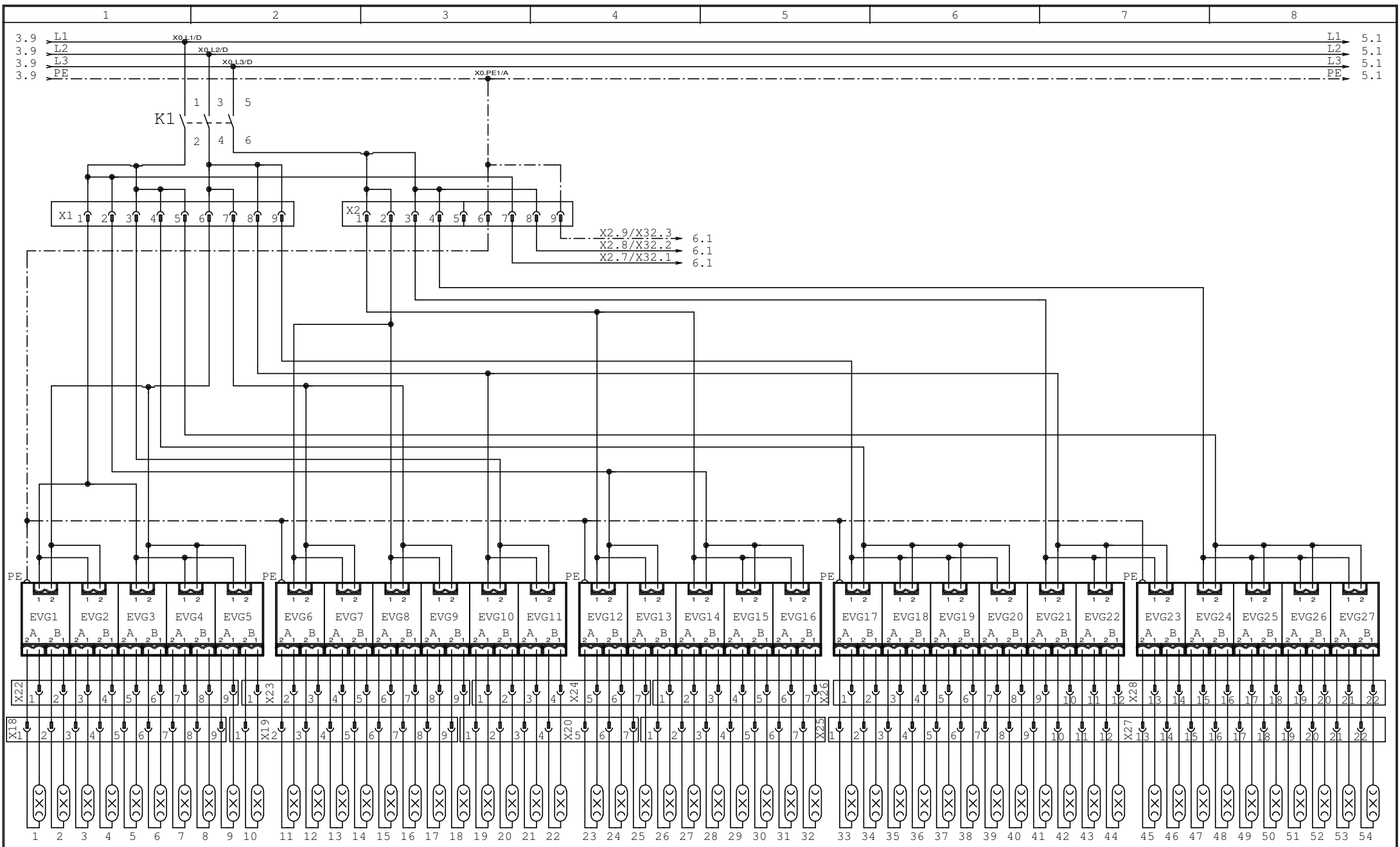

tubes canopy 1 - 25

tubes back side 26 - 30

tubes base 31 - 54

		Datum	17.03.06	 <b>KBI</b> <small>SOLAR INVERTER COMPANY</small>	MS 7900 CPI_USA		= Änderungen vorbehalten		
		Bearb.	R.Schmidt		KBL- Solarien		MS 7900 CPI_USA		
		Gepr.					MS7900_CPI_03/0705us		Blatt 4
Zust.	Änderung	Datum	Name	Norm	Urspr.	Ers.f.	Ers.d.	MS 7900 CPI_USA	von 10Bl.

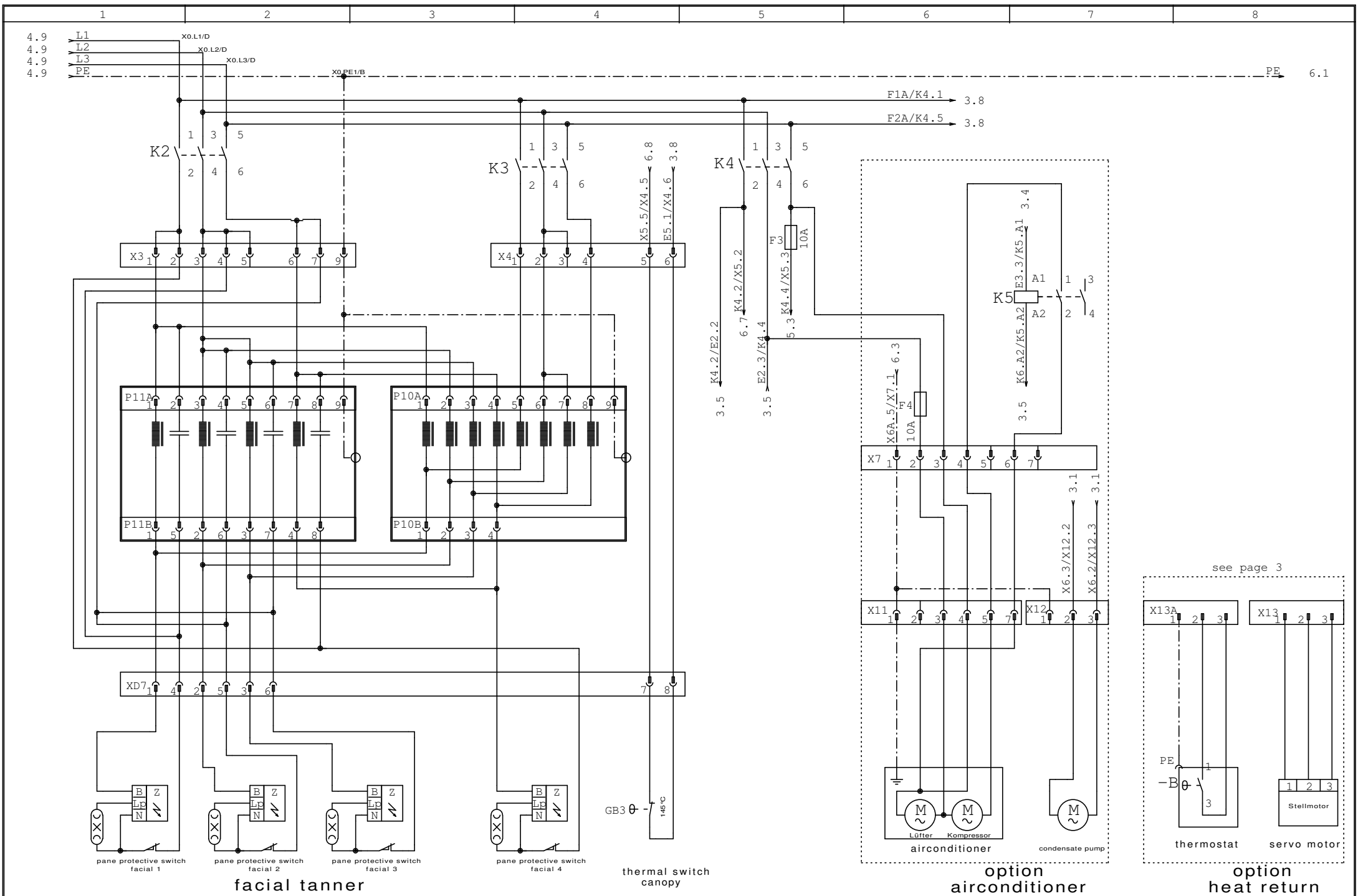

Datum	17.03.06
Bearb.	R.Schmidt
Gepr.	
Zust.	Änderung
Datum	
Name	
Norm	

**KBL- Solarien**

**KBI**  
SOLARIE COMPANY

Urspr.	Ers.f.	Ers.d.
--------	--------	--------

MS 7900 CPI\_USA

MS 7900_CPI_220V_usa	= Änderungen vorbehalten
MS7900_CPI_03/0705us	+ Blatt 5
	von 10Bl.



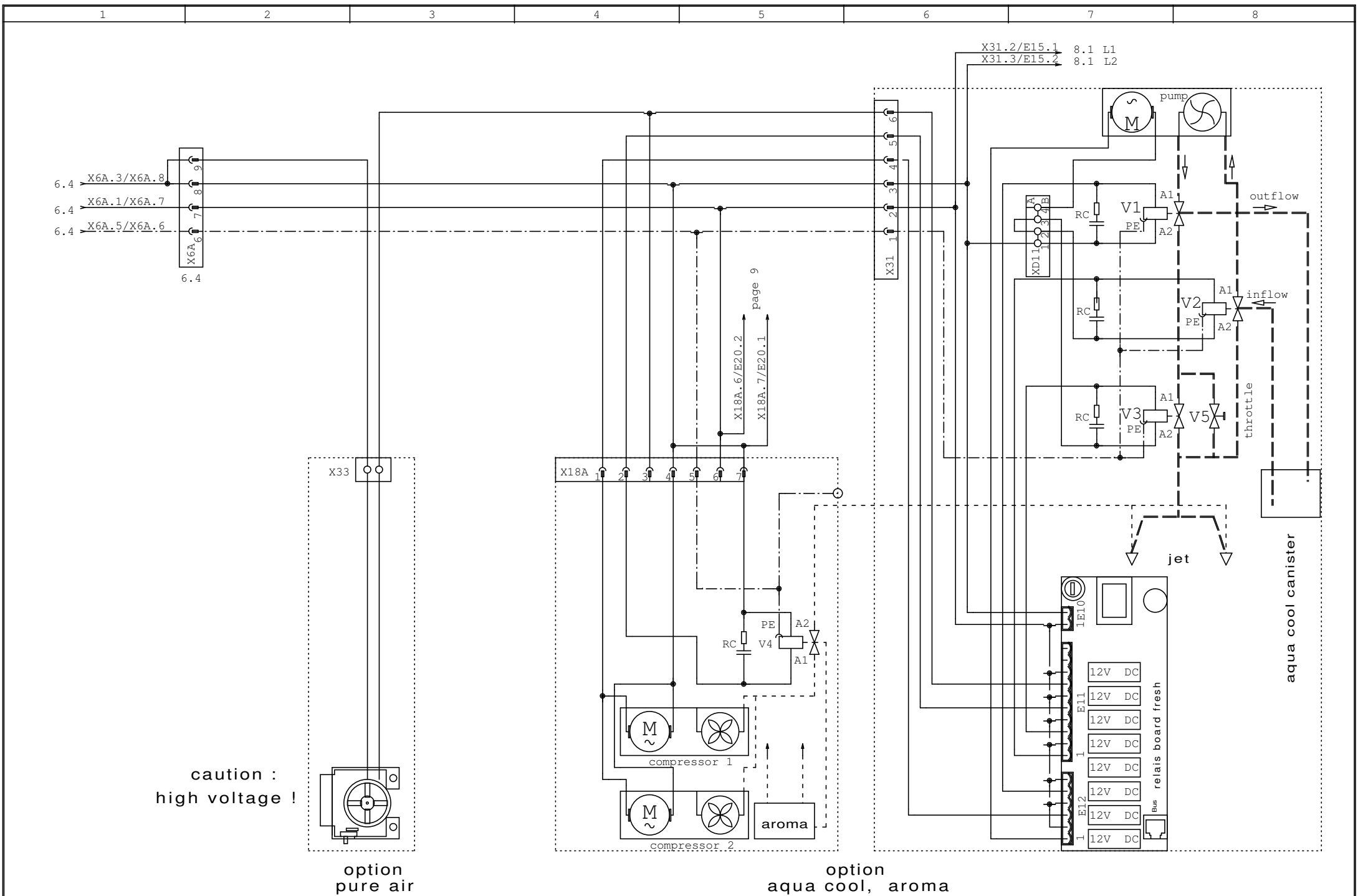

					Datum	17.03.06	KBL- Solarien			MS 7900 CPI_USA		= Änderungen vorbehalten			
					Bearb.	R.Schmidt				MS 7900 CPI_USA		MS7900_CPI_03/0705us		Blatt 7	
					Gepr.					Urspr.		Ers.f.		von 10Bl.	
Zust.	Änderung	Datum	Name	Norm				Ers.d.							

### option wellness color

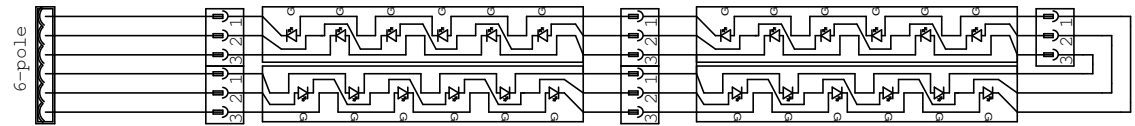
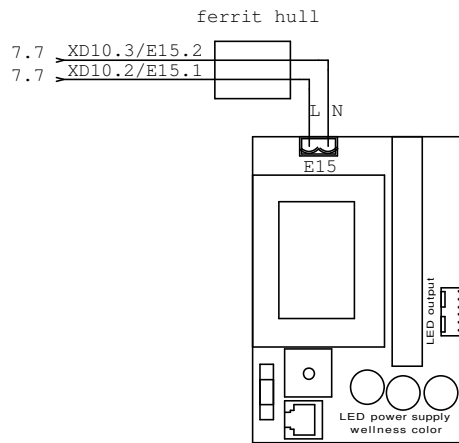

				Datum	17.03.06	KBL- Solarien		MS 7900 CPI_USA	MS 7900_CPI_220V_usa		= Änderungen vorbehalten	
			Bearb.	R.Schmidt							+	
			Gepr.									
Zust.	Änderung	Datum	Name	Norm		Urspr.	Ers.f.	Ers.d.	MS7900_CPI_03/0705us		Blatt 8 von 10Bl.	



top  
(view of above)

base  
(view of above)

canopy

back side

front

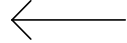

front

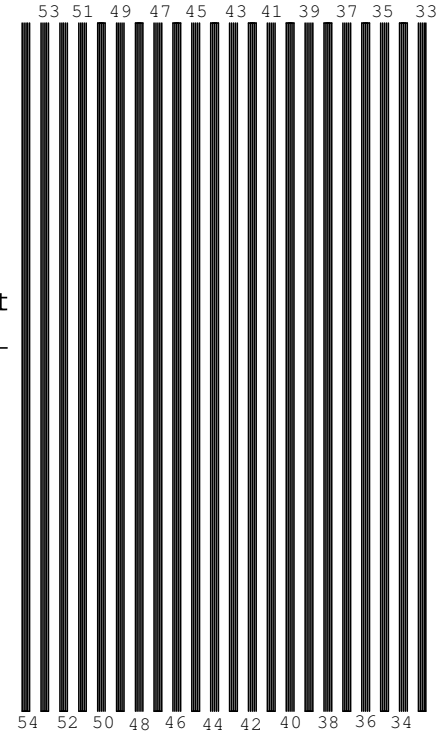
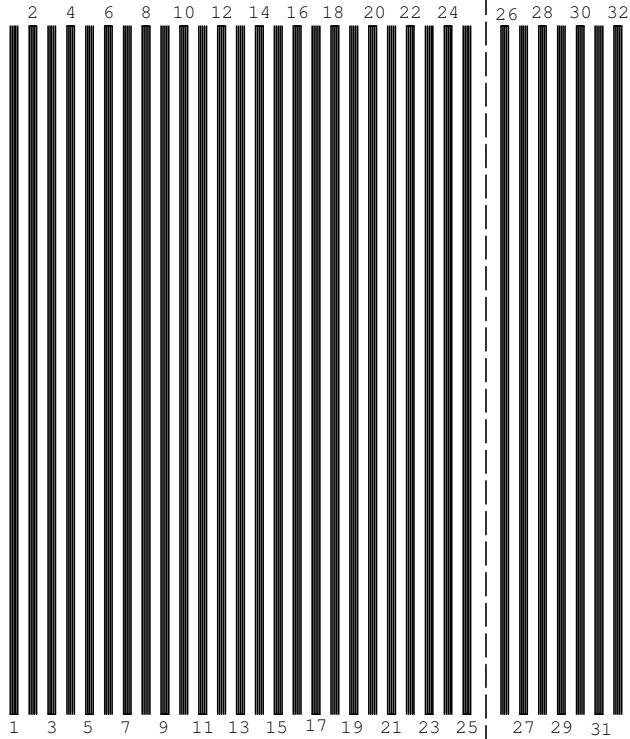
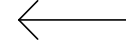

			Datum	17.03.06	KBL- Solarien		MS 7900 CPI_USA	MS7900_CPI_03/0705us	=	Änderungen vorbehalten			
		Bearb.	R.Schmidt									+	
		Gepr.											
Zust.	Änderung	Datum	Name	Norm	Urspr.	Ers.f.	Ers.d.			Blatt 10 von 10Bl.			