

# circuit diagram

# KBL 3500

			Datum	17.03.06				MS 3500_IND_220V_usa	= Änderungen vorbehalten
			Bearb.	R.Schmidt					+
			Gepr.						
Zust.	Änderung	Datum	Name	Norm	Urspr.	Ers.f.	Ers.d.	MS 3500_IND_01/0206us	page 1 von 6Bl.

MS 3500 IND usa

MS 3500\_IND\_220V\_usa

MS 3500\_IND\_01/0206us

### connector and terminals

- X0 control, terminal
- X1 control, facial
- X2 control, canopy tubes 1 - 9
- X3 control, canopy tubes 10-18
- X4 control, canopy tubes / thermal switch
- X5 control, base tubes 19-27
- X6 control, base tubes 29-36
- X7 control, base tubes/deko.light/body ventil.
- X8 control, external timer
- X9 deko lightning base ballast /exhaust air base
- X10 exhaust air base
- X11 canopy, tubes 1-12
- X12 canopy, tubes 13-18 /facial taner
- X13 canopy, tubes
- X14 canopy, tubes
- X15 canopy, exhaust air, thermal switch
- X16 canopy, exhaust air, thermal switch
- X17 base, tubes 19-30
- X18 base, tubes 31-36 /body ventilation
- X19 base, tubes
- X20 base, tubes
- X21 base, exhaust air /deko lightning
- X22 base, body ventilation
- X23 canopy, exhaust air
- X24 channel select
- X25 subwoofer

- E1 main control board, power supply
- E2 main control board, relais output
- E3 main control board, remote start /ch. select
- E4 main control board, error messages /body vent

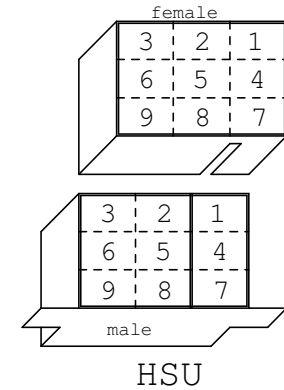

### connection of the main power supply

1 x 220V / 60Hz ~ 3 x AWG 10

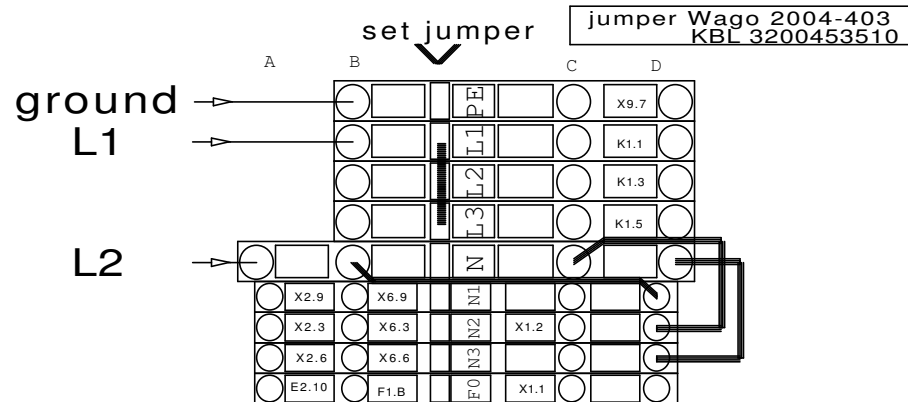

### connection of the main power supply

3 x 220V / 60Hz ~ 4 x AWG 10

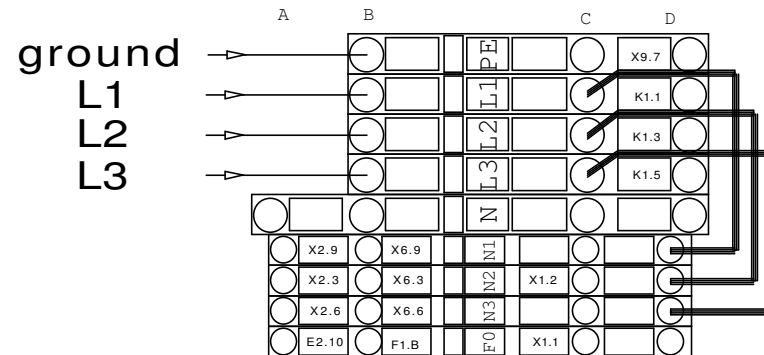

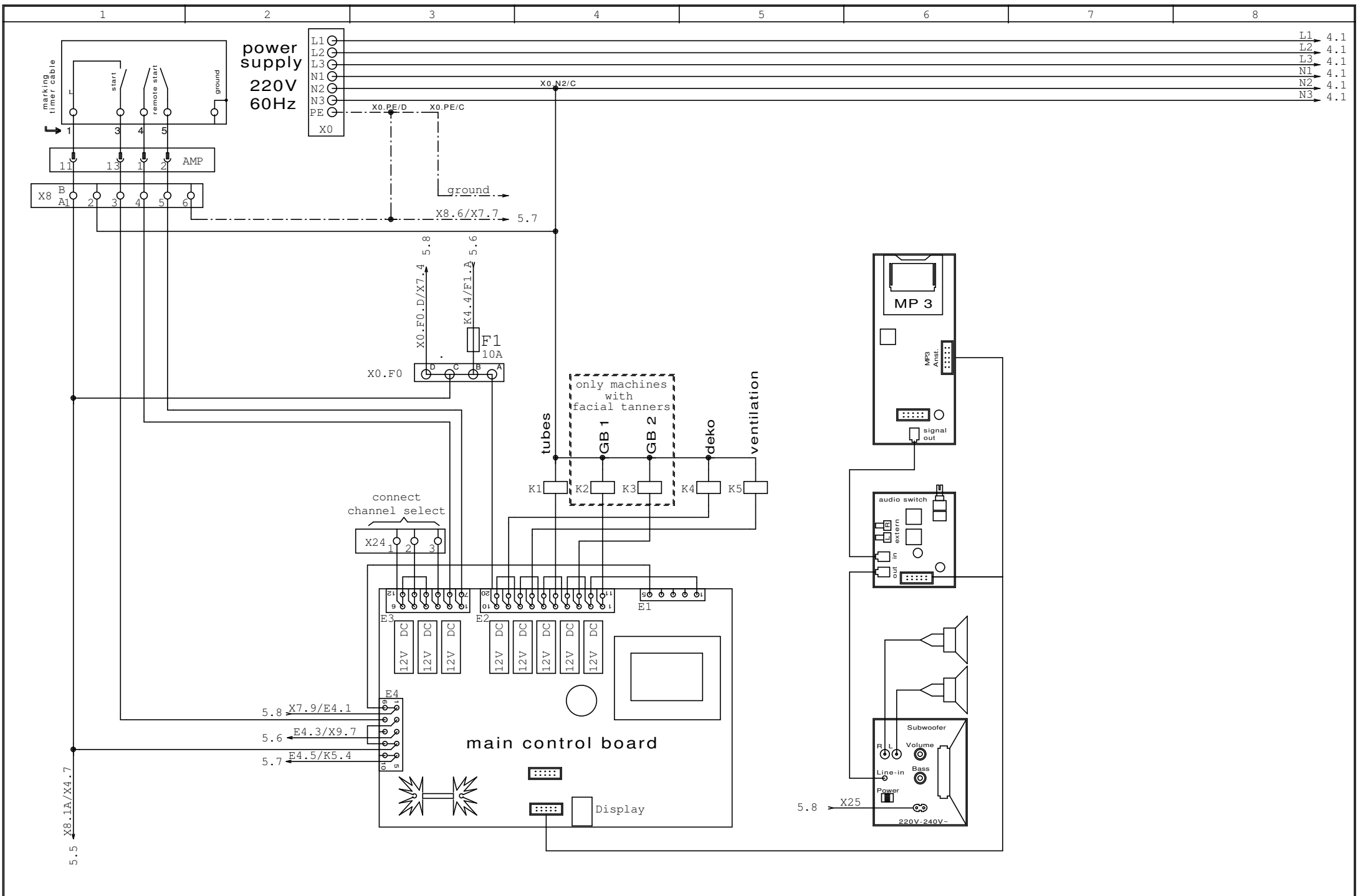

				Datum	17.03.06
				Bearb.	R.Schmidt
				Gepr.	
Zust.	Änderung	Datum	Name	Norm	

Urspr.      Ers.f.      Ers.d.

MS 3500 IND usa

MS 3500_IND_220V_usa	= Änderungen vorbehalten
MS 3500_IND_01/0206us	+ page 3
	von 6Bl.



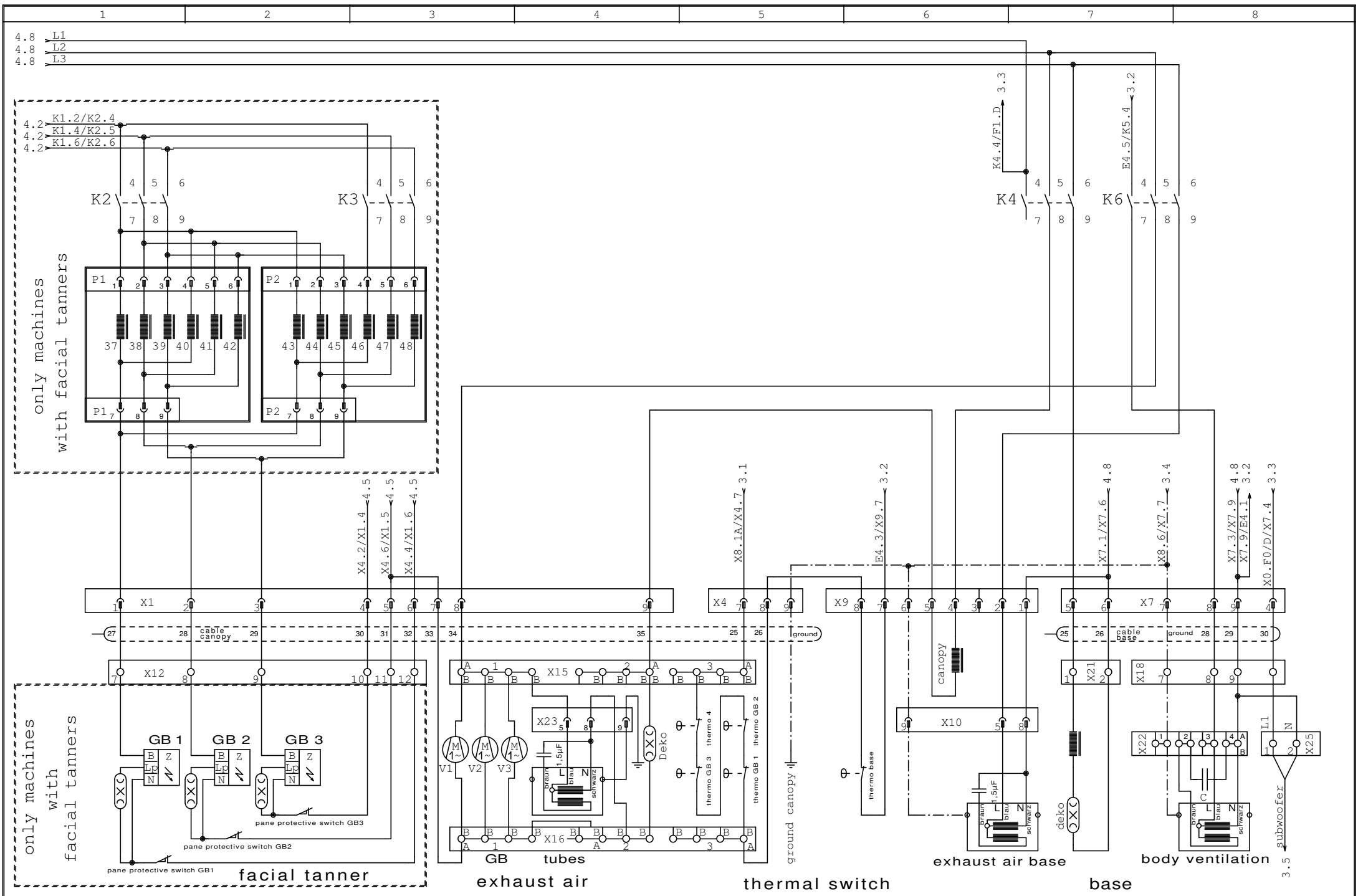

Datum	17.03.06
Bearb.	R.Schmidt
Gepr.	
Zust.	Änderung
Datum	
Name	
Norm	
Urspr.	
Ers.f.	
Ers.d.	



MS 3500 IND usa

MS 3500_IND_220V_usa	= Änderungen vorbehalten
MS 3500_IND_01/0206us	+ page 5
	von 6Bl.

terminal block canopy

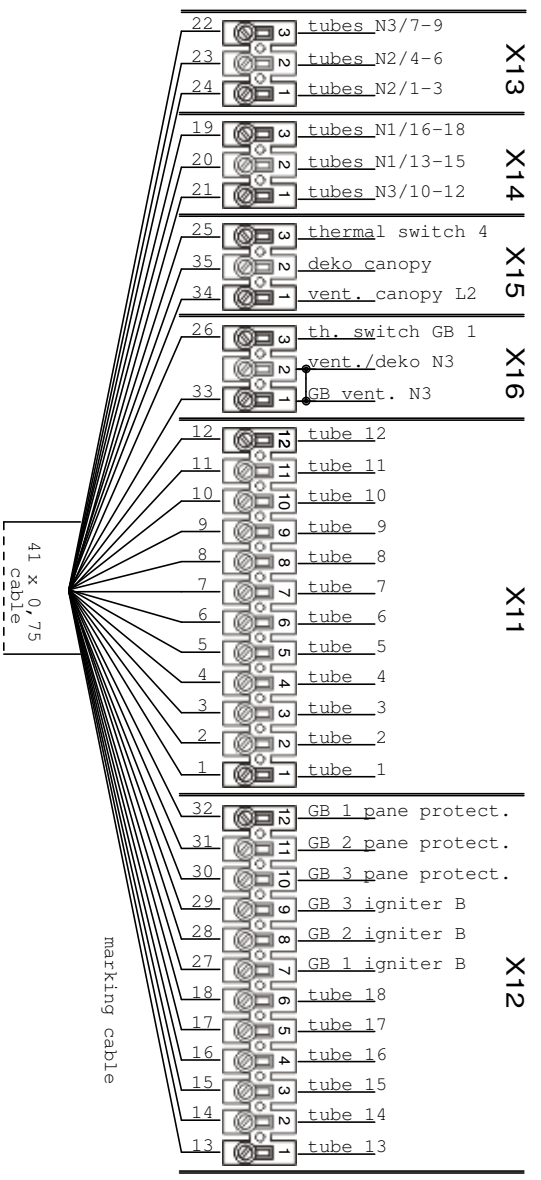

terminal block base

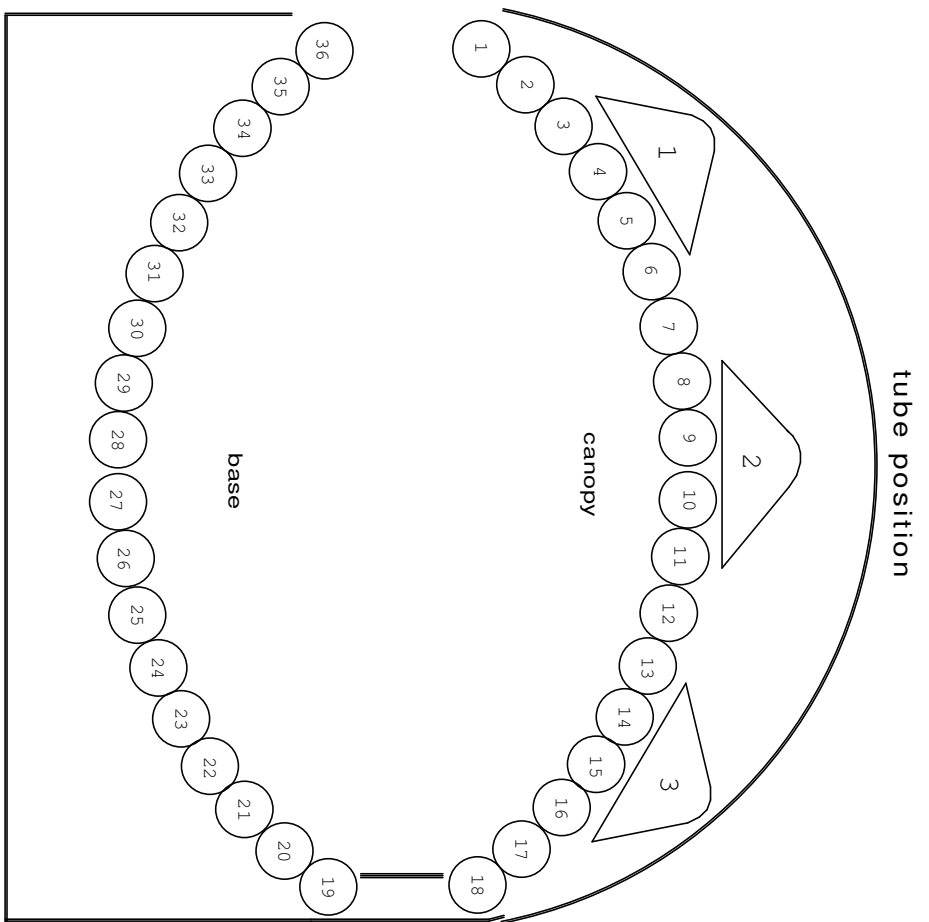
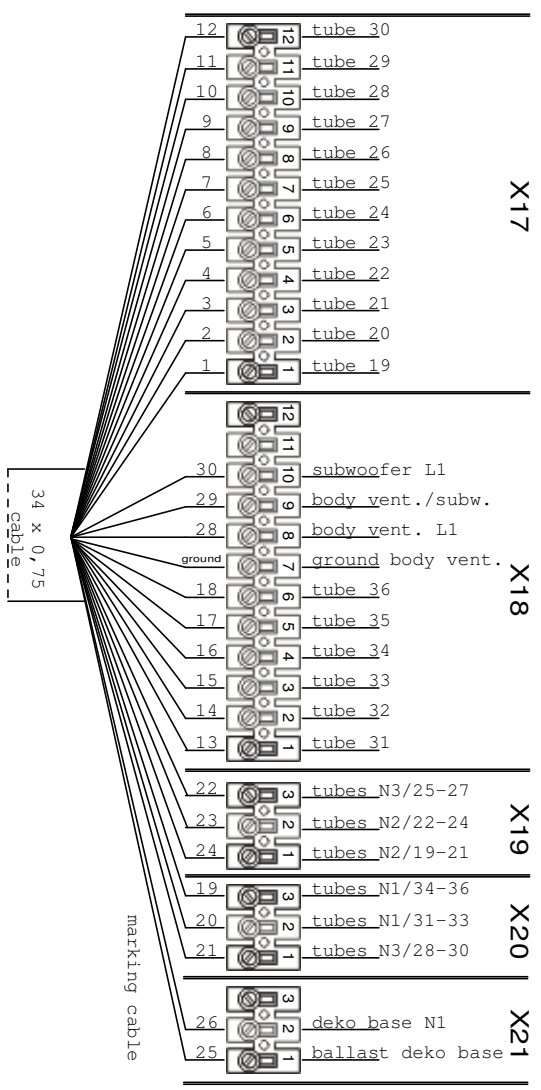

Zust.	Änderung	Datum	17.03.06
		Bearb.	R. Schmidt
		Gepr.	
		Urspr.	
		Ers. f.	
		Ers. d.	



MS 3500 IND usa	MS 3500_IND_220V_usa	=	Änderungen vorbehalten
		+	
			page 6
			von 6 Bl.